

# Light-Reflection and Refraction

## PREVIOUS YEARS' Questions

2007

### SHORT ANSWER TYPE QUESTIONS[II]

[3 Marks]

1. A concave lens has focal length of 20 cm. At what distance from the lens a 5 cm tall object be placed so that it forms an image at 15 cm from the lens? Also calculate the size of the image formed. [Delhi]

Ans.  $f = -20$  cm,  $h_o = 5$  cm,  $v = -15$  cm.

Using,  $\frac{1}{f} = \frac{1}{v} - \frac{1}{u}$ , we get

$$\frac{1}{u} = \frac{1}{v} - \frac{1}{f} = \frac{1}{-15} - \frac{1}{(-20)}$$

$$\frac{1}{u} = \frac{-20 + 15}{300} = -\frac{5}{300}$$

$$u = -60 \text{ cm.}$$

Since,  $m = \frac{h_i}{h_o} = \frac{v}{u}$ , we get

$$h_i = \frac{v}{u} \cdot h_o = \frac{(-15)}{(-60)} \times 5$$

$$= \frac{5}{4} = 1.25 \text{ cm.}$$

Image is diminished and virtual.

2. An object 50 cm tall is placed on the principal axis of a convex lens. Its 20 cm tall image is formed on the screen placed at a distance of 10 cm from the lens. Calculate the focal length of the lens. [All India]

Ans.  $h_o = 50$  cm,

$$h_i = 20 \text{ cm, } v = 10 \text{ cm.}$$

Using,  $m = \frac{h_i}{h_o} = \frac{v}{u}$ , we get

With sign convention,

$$u = v \frac{h_o}{h_i} = 10 \times \frac{50}{(-20)}$$

$$= -25 \text{ cm.}$$

Using,  $\frac{1}{f} = \frac{1}{v} - \frac{1}{u}$ , we get

$$\frac{1}{f} = \frac{1}{10} - \frac{1}{-25} = \frac{25 + 10}{250}$$

$$f = \frac{250}{35} = 7.14 \text{ cm.}$$

# LONG ANSWER TYPE QUESTION

[5 Marks]

3. Draw the ray diagram in each case to show the position and nature of the image formed when the object is placed:

- (i) at the centre of curvature of a concave mirror
- (ii) between the pole P and focus F of a concave mirror
- (iii) in front of a convex mirror
- (iv) at 2F of a convex lens
- (v) in front of a concave lens

[Delhi]

Ans. (i)

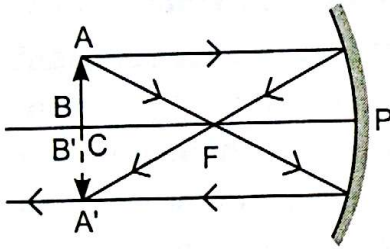

**Nature of image:** Real, inverted and same size image is formed at the centre of curvature.

(ii)

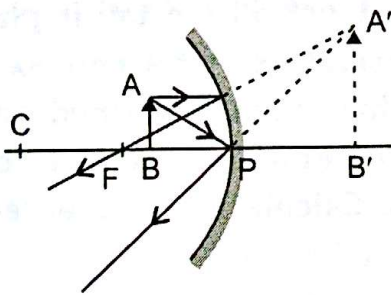

**Nature of image:** Virtual, enlarged and erect image is formed behind the mirror.

(iii)

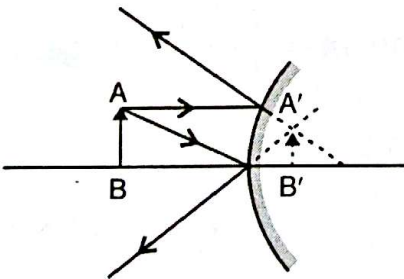

**Nature of image:** Virtual, erect and diminished, image is formed behind the mirror.

(iv)

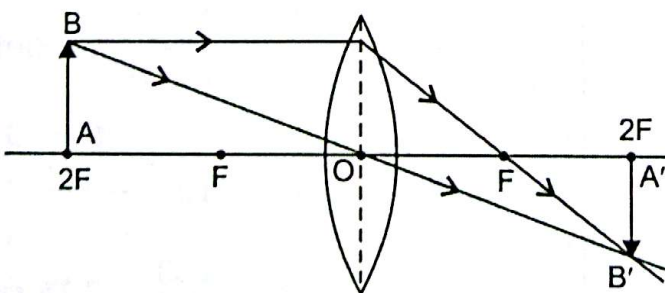

**Nature of image:** Real, inverted and size to size, image is formed at  $2F$  on the other side of lens.

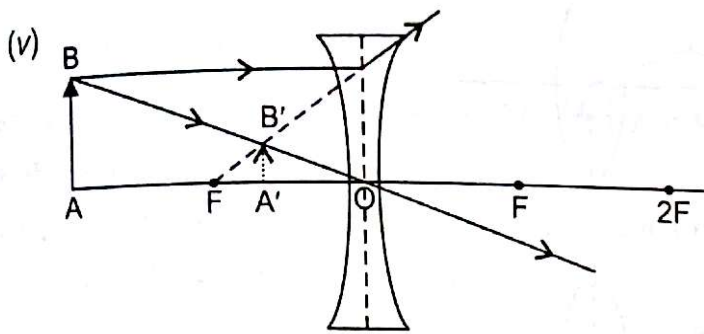

**Nature of image:** Virtual, erect and diminished image is formed between  $O$  and  $F$  on the same side of object.

2008

**VERY SHORT ANSWER TYPE QUESTIONS**

[1 Mark]

4. If a light ray  $IM$  is incident on the surface  $AB$  as shown, identify the correct emergent ray.

[Delhi(C)]

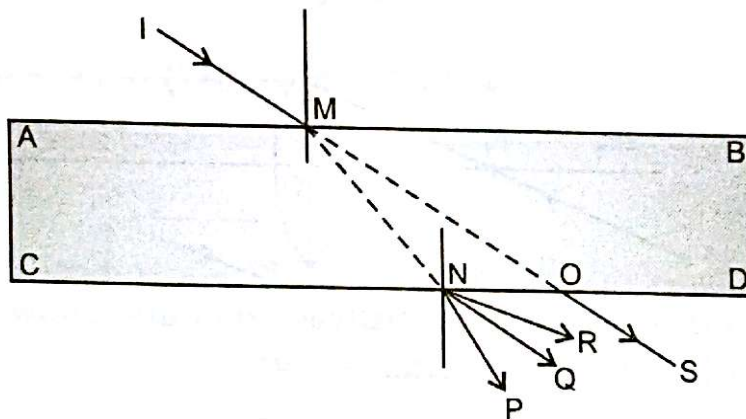

Ans. Ray  $NQ$ , as it has to be parallel to ray  $OS$ .

5. The refractive indices of four media  $A$ ,  $B$ ,  $C$  and  $D$  are given in the following table:

Medium	A	B	C	D
Refractive Index	1.33	1.50	1.52	2.40

If light travels from one medium to another, in which case the change in speed will be (i) minimum, (ii) maximum?

[Delhi(C)]

Ans. (i) Minimum change is seen as light moves between 1.50 and 1.52, i.e.  $B$  and  $C$ .  
 (ii) Maximum change when light moves between 1.33 and 2.40, i.e.  $A$  and  $D$ .

6. "The refractive index of diamond is 2.42". What is the meaning of this statement in relation to speed of light?

[Delhi]

Ans. Since,  $v = \frac{c}{n}$ ,  $n = 2.42$  means that the speed of light in diamond is  $\frac{1}{2.42}$  times the speed of light in free space.

7. Redraw the given diagram and show the path of the refracted ray:

[All India(C)]

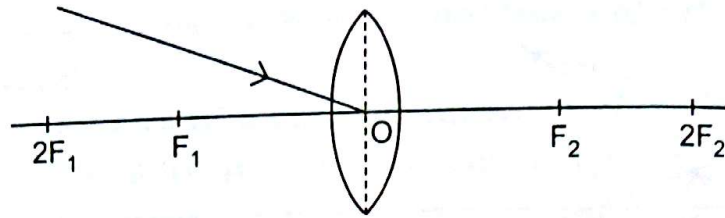

Ans.

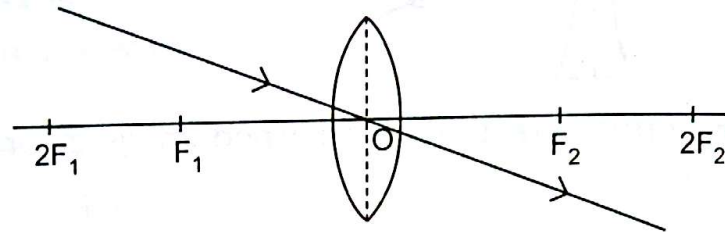

8. Redraw the given diagram and show the path of the refracted ray:

[All India(C)]

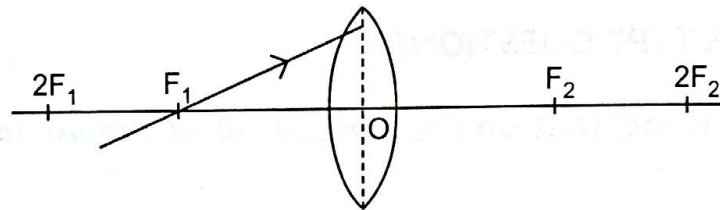

Ans.

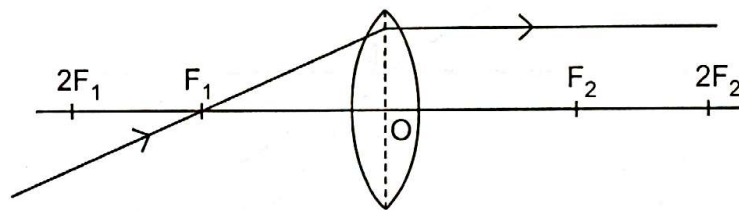

9. Draw the following diagram in your answer book and show the formation of image of the object AB with the help of suitable rays.

[All India]

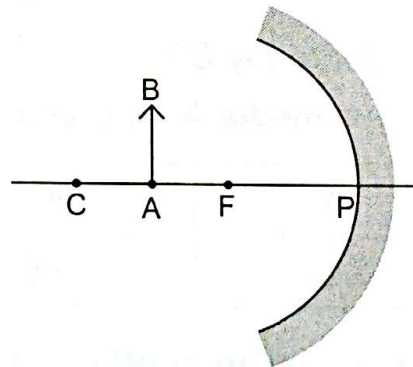

Ans.

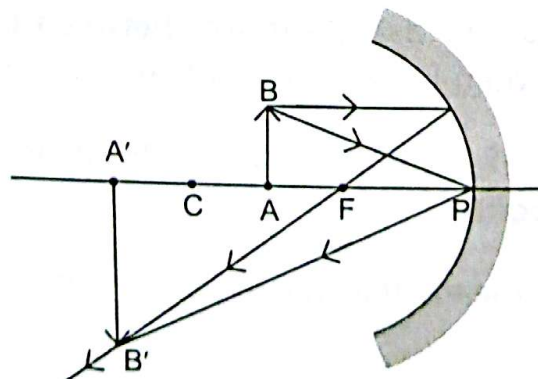

10. Which kind of mirrors are used in the headlights of a motor-car and why? [Foreign]  
 Ans. Concave mirror, to get the parallel beam of light.

**SHORT ANSWER TYPE QUESTIONS[I]**

[2 Marks]

11. Explain with the help of a diagram, why a pencil partly immersed in water appears to be bent at the water surface. [Delhi]

Ans. Light from different points on the pencil, immersed in water refracts and appears to come from a point above the original position.

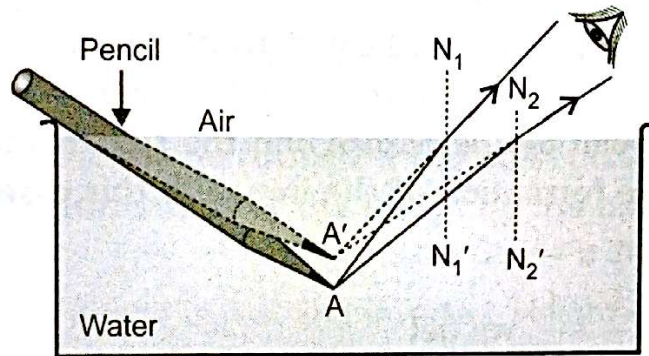

12. Draw ray diagrams to represent the nature, position and relative size of the image formed by a convex lens for the object placed:

(a) at  $2F_1$ .

(b) between  $F_1$  and the optical centre O of lens:

[All India]

Ans. (a) At  $2F_1$

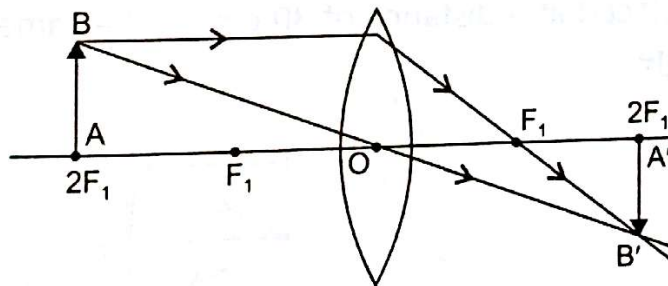

**Nature:** Real, inverted, size to size.

**Position:** At  $2F$ .

(b) Between  $F_1$  and the optical centre O of lens

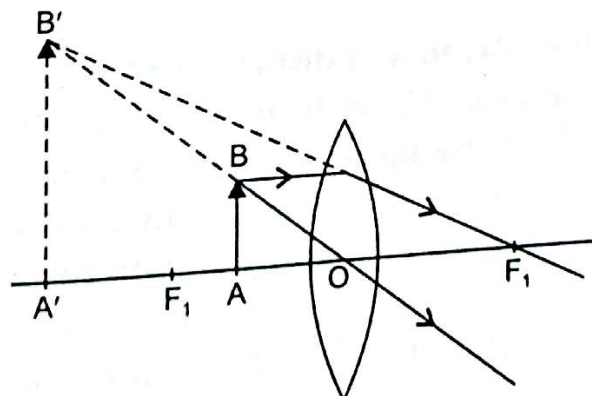

**Nature:** Virtual, erect, enlarged.

**Position:** On the same side of the lens.

13. A ray of light, incident obliquely on a face of a rectangular glass slab placed in air, emerges from the opposite face parallel to the incident ray. State two factors on which the lateral displacement of the emergent ray depends. [Foreign]

Ans. Lateral displacement depends on the:

- (i) angle of incidence,
- (ii) thickness of slab, and
- (iii) refractive index of the material.

(any two)

### SHORT ANSWER TYPE QUESTIONS[II]

[3 Marks]

14. An object 2 cm in size is placed 30 cm in front of a concave mirror of focal length 15 cm. At what distance from the mirror should a screen be placed in order to obtain a sharp image? What will be the nature and the size of the image formed? Draw a ray diagram to show the formation of the image in this case. [Delhi(C)]

Ans.  $f = -15$  cm,  $h_o = 2$  cm,  $u = -30$  cm.

Using,  $\frac{1}{f} = \frac{1}{v} + \frac{1}{u}$ , we get

$$\begin{aligned} \frac{1}{v} &= \frac{1}{f} - \frac{1}{u} = \frac{1}{-15} - \frac{1}{-30} \\ &= \frac{2-1}{-30} = \frac{1}{-30} \end{aligned}$$

$$\Rightarrow v = -30 \text{ cm}$$

So, screen should be placed at a distance of 30 cm on the same side of the object in order to obtain a sharp image.

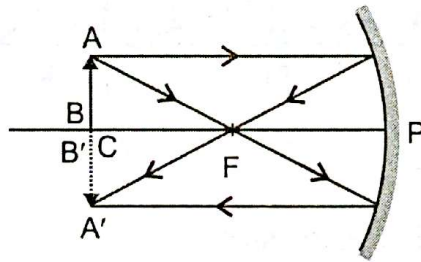

Since,  $|v| = |u| = 2f$ , it means that the object is placed at the centre of curvature (C) of a concave mirror, the image formed is at the centre of curvature, real and inverted and of the same size as the object.

15. An object 2 cm high is placed at a distance of 64 cm from a white screen. On placing a convex lens at a distance of 32 cm from the object it is found that a distinct image of the object is formed on the screen. What is the focal length of the convex lens and size of the image formed on the screen? Draw a ray diagram to show the formation of the image in this position of the object with respect to the lens. [Delhi(C)]

Ans. Since, object-screen distance is double of object-lens separation, the object is at a distance of  $2f$  from the lens and the image should be of the same size of the object.

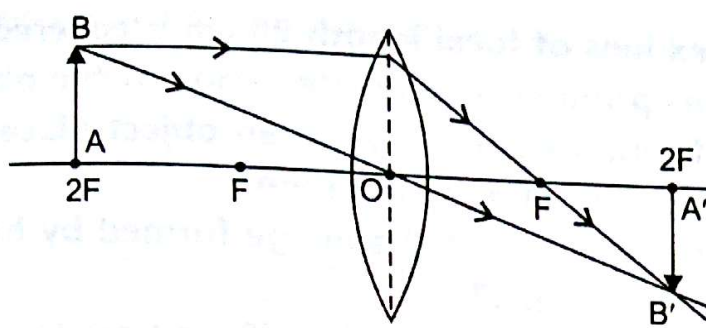

So,  $2f = 32 \Rightarrow f = 16 \text{ cm}$

Height of image = Height of object = 2 cm.

16. A convex lens has a focal length of 10 cm. At what distance from the lens should the object be placed so that it forms a real and inverted image 20 cm away from the lens? What would be the size of the image formed if the object is 2 cm high? With the help of a ray diagram show the formation of the image by the lens in this case.

[All India(C)]

Ans.  $f = +10 \text{ cm}$ ,  $v = +20 \text{ cm}$  as image is real and inverted. Height of the object = 2 cm. (Say +ve)

Using,  $\frac{1}{f} = \frac{1}{v} - \frac{1}{u}$ , we get

$$\frac{1}{u} = \frac{1}{v} - \frac{1}{f}$$

$$= \frac{1}{+20} - \frac{1}{10} = \frac{+1-2}{20} = -\frac{1}{20}$$

$\therefore u = -20 \text{ cm} (= 2f)$

Object is placed at 2F, image is also formed at 2F on the other side of the lens. So, image will be of the same size as the object as  $|u| = |v|$  and, therefore, the height of the image will be 2 cm.

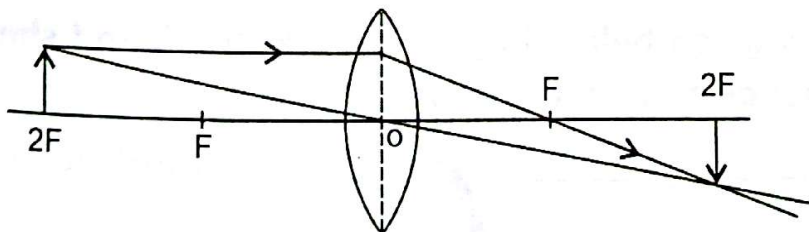

LONG ANSWER TYPE QUESTION

[5 Marks]

17. (a) It is desired to obtain an erect image of an object, using a concave mirror of focal length 20 cm.
- What should be the range of distance of the object from the mirror?
  - Will the image be bigger or smaller than the object?
  - Draw a ray diagram to show the image formation in this case.

- (b) One half a convex lens of focal length 20 cm is covered with a black paper.
- Will the lens produce a complete image of the object?
  - Show the formation of image of an object placed at  $2F_1$  of such covered lens with the help of a ray diagram.
  - How will the intensity of the image formed by half-covered lens compare with non-covered lens?

[Foreign]

- Ans. (a) (i) Range of the object distance is 0 to 20 cm from the pole.  
 (ii) Image will be bigger than the object.  
 (iii) Ray diagram:

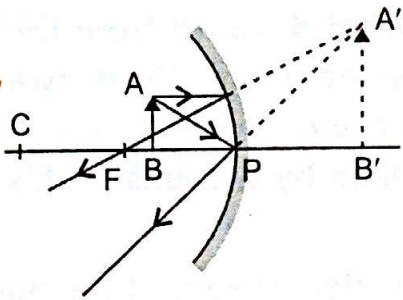

- (b) (i) Yes, complete image will be formed.

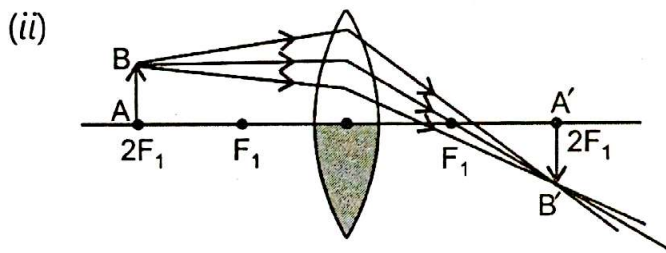

- (iii) Intensity will be reduced as the light falling on the lower (covered) portion will not reach the position of image.

2009

VERY SHORT ANSWER TYPE QUESTIONS

[1 Mark]

18. Redraw the diagram given below in your answer book and show the direction of the light ray after reflection from the mirror. [Delhi(C)]

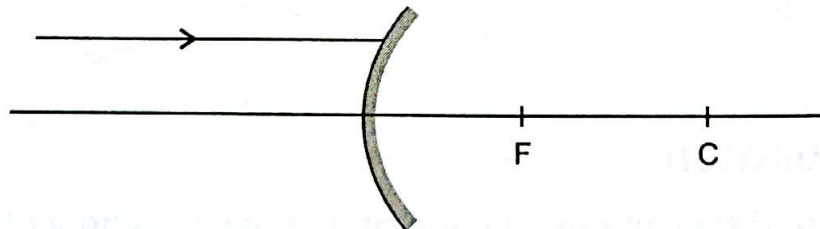

Ans.

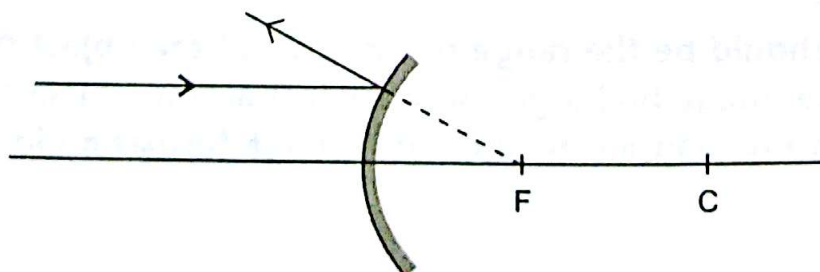



19. Redraw the diagram given below in your answer book and show the direction of the light ray after reflection from the mirror. [Delhi(C)]

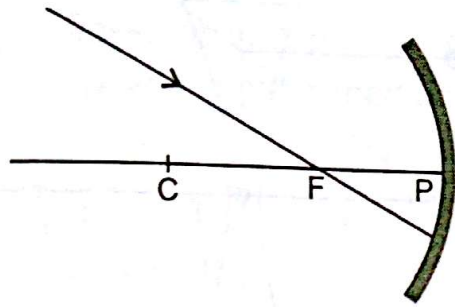

Ans.

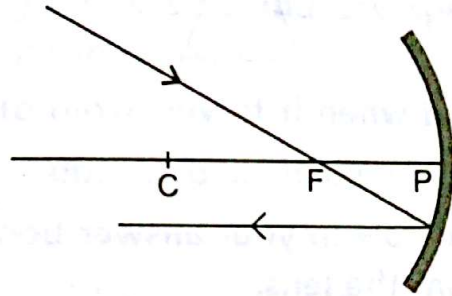

20. Redraw the diagram given below in your answer book and show the direction of the light ray after reflection from the mirror. [Delhi(C)]

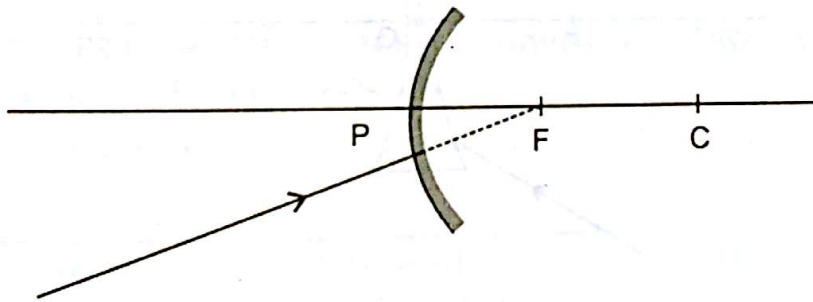

Ans.

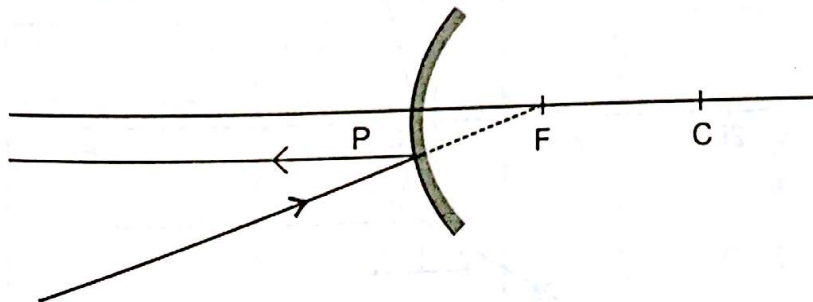

21. Redraw the diagram given below in your answer book and show the direction of the light ray after refraction from the lens. [Delhi, All India(C)]

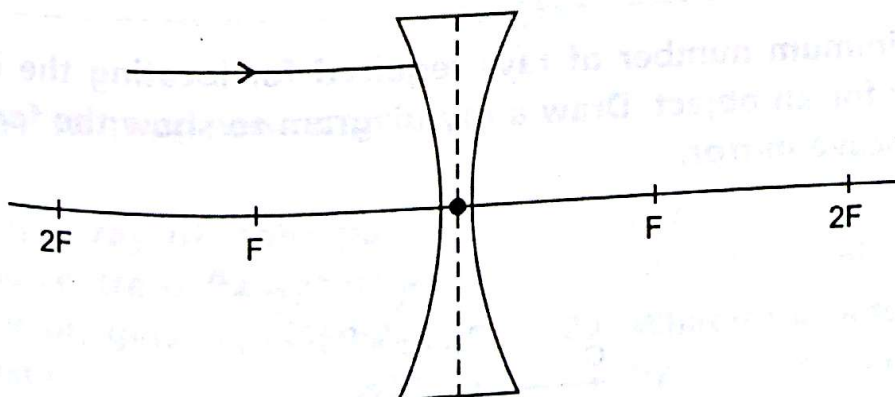

Ans.

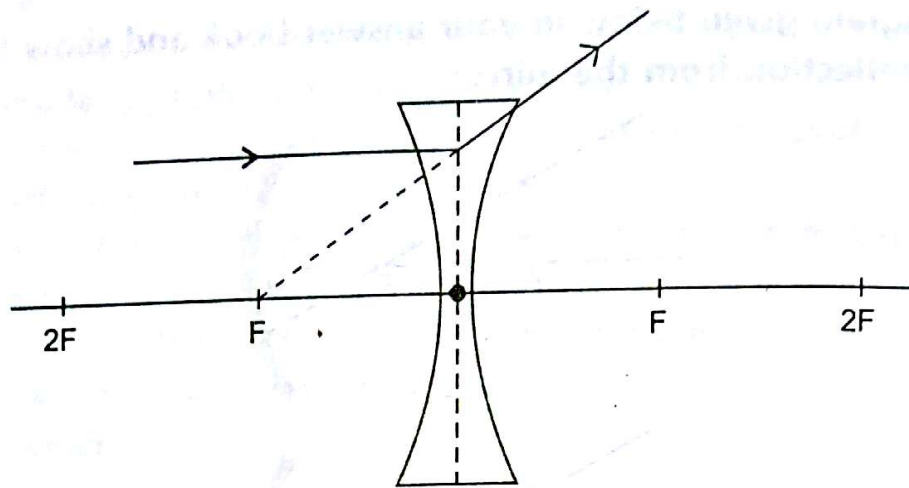

22. Why does a ray of light bend when it travels from one medium into another? [Delhi]

Ans. Due to change in velocity in the medium and to reduce the time taken to travel the same.

23. Redraw the diagram given below in your answer book and show the direction of the light ray after refraction from the lens. [All India(C)]

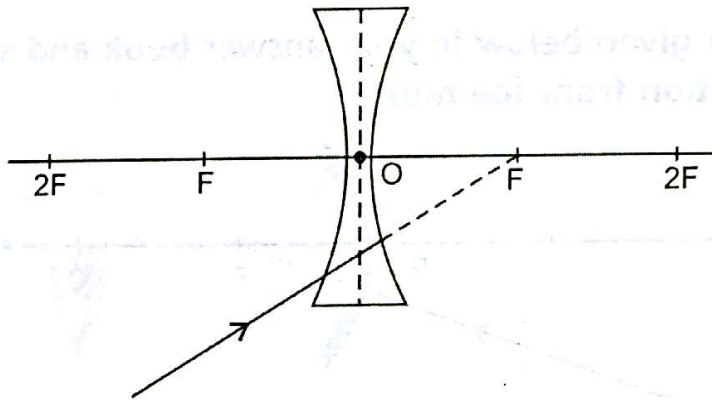

Ans.

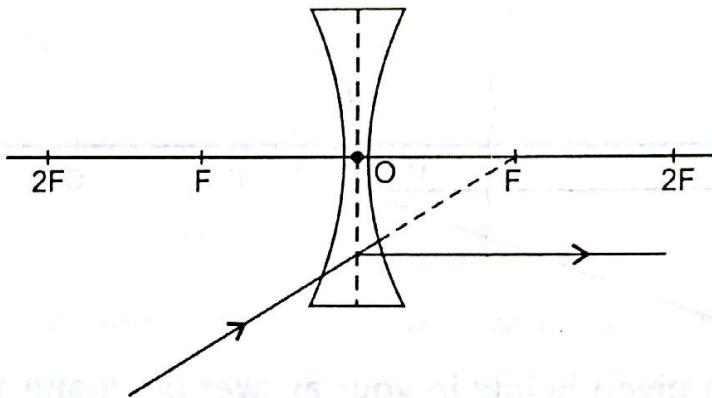

SHORT ANSWER TYPE QUESTIONS[I]

[2 Marks]

24. What is the minimum number of rays required for locating the image formed by a concave mirror for an object. Draw a ray diagram to show the formation of a virtual image by a concave mirror. [Delhi]

Ans. Two rays.

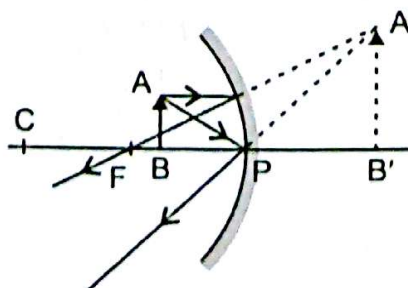

25. The refractive index of water is 1.33 and the speed of light in air is  $3 \times 10^8 \text{ ms}^{-1}$ . Calculate the speed of light in water. [Foreign]

Ans. Since, refractive index  $= n = \frac{\text{Speed of light in vacuum}}{\text{Speed of light in medium}} = \frac{c}{v}$

$$\text{we get, } v = \frac{c}{n} = \frac{3 \times 10^8}{1.33} = \frac{3 \times 10^8}{4} \times 3$$

$$= 2.25 \times 10^8 \text{ ms}^{-1}.$$

26. The refractive index of glass is 1.50 and the speed of light in air is  $3 \times 10^8 \text{ ms}^{-1}$ . Calculate the speed of light in glass. [Foreign]

Ans. Since refractive index  $= n$

$$= \frac{\text{Speed of light in vacuum}}{\text{Speed of light in the medium}} = \frac{c}{v}$$

$$\text{we have, } v = \frac{c}{n} = \frac{3 \times 10^8}{1.50} = 2 \times 10^8 \text{ ms}^{-1}.$$

### SHORT ANSWER TYPE QUESTION [II]

[3 Marks]

27. For which position of the object does a convex lens form a virtual and erect image? Explain with the help of a ray diagram. [All India]

Ans. When the object is placed between the focus and the optical centre, a virtual and erect image is formed.

Position of Object	Position of Image	Nature of Image	Ray Diagram
Between F and optical centre	On the same side of the lens	Virtual, erect and enlarged	

2010

### VERY SHORT ANSWER TYPE QUESTIONS

[1 Mark]

28. Explain why a ray of light passing through the centre of curvature of a concave mirror, gets reflected along the same path. [Delhi]

Ans. The ray passing through the centre of curvature incident to the mirror along its

normal so  $\angle i = \angle r = 0$ . Therefore, the ray retraces its path.

29. What is the nature of the image formed by a concave mirror if the magnification produced by the mirror is +3? [Delhi]

**Ans.** Positive sign of magnification indicates that image is virtual, erect and enlarged.

**30. Between which two points of a concave mirror should an object be placed to obtain a magnification of  $-3$ ? [Delhi]**

**Ans.** Negative sign of magnification indicates that image is real and inverted. Also size of image is enlarged. So, object must be positioned between  $F$  and  $2F$ , i.e.  $C$ .

**31. "The refractive index of carbon disulphide is 1.63." What is the meaning of this statement in relation to speed of light? [Delhi]**

**Ans.** Speed of light in carbon disulphide is  $\frac{1}{1.63}$  times the speed of light in free space.

**32. The outer surface of a hollow sphere of aluminium of radius 50 cm is to be used as a mirror. What will be the focal length of this mirror? Which type of spherical mirror will it provide? [Delhi]**

**Ans.**  $f = \frac{R}{2} = 25 \text{ cm}$

It will form a convex mirror.

**33. Between which two points related to a concave mirror should an object be placed to obtain on a screen an image twice the size of the object? [All India]**

**Ans.** Real Image: Between  $F$  and  $C$ .

**34. How should a ray of light be incident on a rectangular glass slab so that it comes out from the opposite side of the slab without being displaced?**

[Foreign]

**Ans.** Along the normal to the surface or at an incident angle of  $i = 0^\circ$ .

**35. A girl was playing with a thin beam of light from her laser torch by directing it from different directions on a convex lens held vertically. She was surprised to see that in a particular direction the beam of light continues to move along the same direction after passing through the lens. State the reason for this observation. [Foreign]**

**Ans.** A ray of light passing through the optical centre of the convex lens will continue to move along the same direction after refracting through the lens.

**36. A ray of light enters a rectangular glass slab of refractive index 1.5. It is found that the ray emerges from the opposite face of the slab without being displaced. If its speed in air is  $3 \times 10^8 \text{ ms}^{-1}$  then what is its speed in glass?**

[Foreign]

**Ans.** Since,  $n = \frac{c}{v}$

we get,  $v = \frac{c}{n} = \frac{3 \times 10^8}{1.5} = 2 \times 10^8 \text{ m/s}$ .

**37. The speed of light in a transparent medium is 0.6 times that of its speed in vacuum. What is the refractive index of the medium? [Foreign]**

**Ans.** Since,  $n = \frac{c}{v}$

we get,  $n = \frac{c}{0.6c} = \frac{1}{0.6} \approx 1.67$

### SHORT ANSWER TYPE QUESTION [I]

[2 Marks]

**38. In an experiment with a rectangular glass slab, a student observed that a ray of light incident at an angle of  $55^\circ$  with the normal on one face of the slab, after refraction strikes the opposite face of the slab before emerging out**

into air making an angle of  $40^\circ$  with the normal. Draw a labelled diagram to show the path of this ray. What value would you assign to the angle of refraction and angle of emergence? [All India]

Ans.

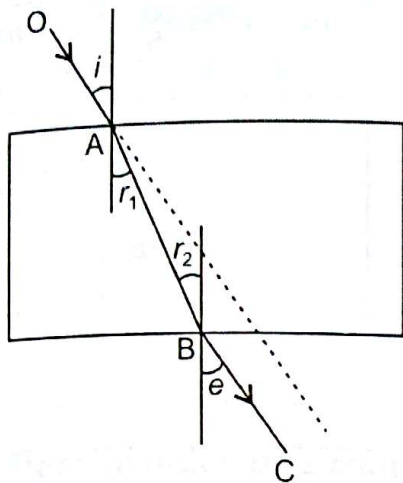

OA – incident ray

$i$  is angle of incidence =  $55^\circ$

Given  $r_2 = 40^\circ$

$r_1$  and  $r_2$  are alternate interior angles,

$$\therefore \angle r_1 = \angle r_2 = 40^\circ$$

So, angle of refraction =  $40^\circ$

Since, the emergent ray is parallel to the incident ray, the angle of emergent must be equal to angle of incidence, i.e.  $\angle e = \angle i = 55^\circ$

### SHORT ANSWER TYPE QUESTIONS [III]

[3 Marks]

39. At what distance should an object be placed from a convex lens of focal length 18 cm to obtain an image at 24 cm from it on the other side. What will be the magnification produced in this case? [Delhi]

Ans.  $f = +18$  cm,  $v = 24$  cm

Using,  $\frac{1}{f} = \frac{1}{v} - \frac{1}{u}$ , we get,  $\frac{1}{u} = \frac{1}{v} - \frac{1}{f}$

$$= \frac{1}{24} - \frac{1}{18} = \frac{3-4}{72}$$

$$\Rightarrow u = -72 \text{ cm.}$$

Object should be kept at a distance of 72 cm on the left side of the convex lens.

Magnification,  $m = +\frac{v}{u} = \frac{24}{-72} = \frac{-1}{3}$

Image is inverted, real and diminished.

40. How far should an object be placed from a convex lens of focal length 20 cm to obtain its image at a distance of 30 cm from the lens? What will be the height of the image if the object is 6 cm tall? [All India]

Ans.  $f = +20$  cm,  $v = +30$  cm

Using,  $\frac{1}{f} = \frac{1}{v} - \frac{1}{u}$

we get,  $\frac{1}{u} = \frac{1}{v} - \frac{1}{f}$   
 $= \frac{1}{30} - \frac{1}{20} = \frac{2-3}{60} = \frac{-1}{60}$

$$\therefore u = -60 \text{ cm.}$$

Object should be placed at a distance of 60 cm on the left side of the convex lens.

Using,  $m = \frac{h_i}{h_o} = +\frac{v}{u}$  we get,

Height of the image,  $h_i = +\frac{v}{u}h_o$   
 $= +\frac{30}{(-60)} \times 6 = -3 \text{ cm}$

Negative sign shows that the image is inverted and real.

41. The image of an object placed at 60 cm in front of a lens is obtained on a screen at a distance of 120 cm from it. Find the focal length of the lens. What would be the height of the image if the object is 5 cm high? [Foreign]

Ans.  $u = -60$  cm,  $v = +120$  cm

Using,  $\frac{1}{f} = \frac{1}{v} - \frac{1}{u}$ , we get

$$\frac{1}{f} = \frac{1}{120} - \frac{1}{-60} = \frac{1+2}{120}$$

⇒

$$f = 40 \text{ cm}$$

$$m = \frac{v}{u} = \frac{h_i}{h_o}$$

∴

$$h_i = h_o \times \frac{v}{u}$$

$$= 5 \times \frac{120}{60} = 10 \text{ cm.}$$

**2011**

**SHORT ANSWER TYPE QUESTIONS[I]**

[2 Marks]

**42. State the two laws of reflection of light.** [Delhi]

**Ans.** Laws of reflection of light are:

- (i) The angle of incidence is equal to the angle of reflection.
- (ii) The incident ray, the normal to the reflecting surface at the point of incidence and reflected ray from that point, all lies in the same plane.

**43. Define and show on a diagram, the following terms relating to a concave mirror:**

- (i) Aperture
- (ii) Radius of curvature [Foreign]

**Ans.** (i) The diameter of the reflecting surface of the mirror is called aperture.

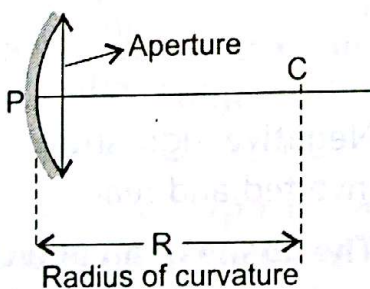

(ii) The radius of the sphere of which the reflecting surface of the spherical

mirror forms a part is called the radius of curvature of the mirror.

**44. Define the focus of a concave mirror. If the radius of curvature of a convex mirror is 30 cm, what would be its focal length?** [Foreign]

**Ans.** The point on the principal axis where all the rays parallel to it meet after reflection is called focus. Since,  $R = 30 \text{ cm}$  and  $f = \frac{R}{2}$  we have,  $f = +15 \text{ cm}$  for a convex mirror.

**45. Distinguish between a real and a virtual image of an object. What type of image is formed (i) by a plane mirror, (ii) on a cinema screen?** [Foreign]

**Ans.** If light rays after reflection converge to a point to form an image on its own, it is called a real image. If they are diverging, then they form a virtual image. Real image can be obtained on a screen, while a virtual image cannot be.

- (i) Plane mirror forms virtual image.
- (ii) On cinema screen, real image is formed.

**SHORT ANSWER TYPE QUESTIONS[II]**

[3 Marks]

**46. Draw a ray diagram and also state the position, the relative size and the nature of image formed by a concave mirror when the object is placed at the centre of curvature of the mirror.** [Delhi]

[Delhi]

Ans.	Position of object	Position of image	Nature of image	Ray diagram
	At C	At C	Real, inverted and of same size.	

47. Define 'refractive index of a transparent medium.' What is its unit? Which has a higher refractive index, glass or water? [Delhi]

Ans. The ratio of the speed of light in the free space ( $c$ ) to the speed of light in given medium ( $v$ ) is called its refractive index.

$$n = \frac{c}{v}$$

It has no unit. Glass has more refractive index than water.

48. A ray of light travelling in air enters obliquely into water. Does the light ray bend towards or away from the normal? Why? Draw a ray diagram to show the refraction of light in this situation. [Delhi]

Ans. Light bends towards the normal because water is denser than air.

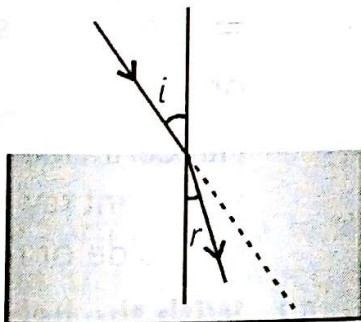

$i$  = Angle of incidence  
 $r$  = Angle of refraction  
 $r < i$

The ray bends towards the normal because it has to travel with a lesser speed in water but with shorter time.

49. (a) "The refractive index of diamond is 2.42". What is the meaning of this statement?

(b) Name a liquid whose mass density is less than that of water but it is optically denser than water. [Delhi]

Ans. (a) This means that the ratio of speed of light in air and the speed of light in diamond is equal to 2.42.

(b) Kerosene

50. An object is placed between infinity and the pole of a convex mirror. Draw a ray diagram and also state the position, the relative size and the nature of the image formed. [All India]

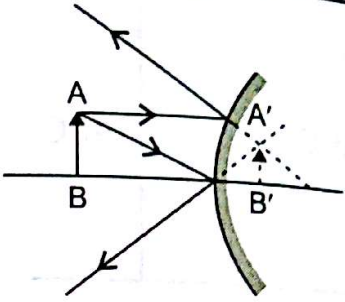
Ans.	Position of Object	Position of Image	Nature of Image	Ray Diagram
	Between infinity and pole P of the mirror	Between P and F and behind the mirror	Virtual, erect and diminished	

**51. What is the principle of reversibility of light? Show that the incident ray of light is parallel to the emergent ray of light when light falls obliquely on a side of a rectangular glass slab.**

[All India]

**Ans.** The final path of the ray of light after reflections or refractions is reversed; the ray retraces its entire path. This principle is called reversibility of light.

For rectangular glass slab,

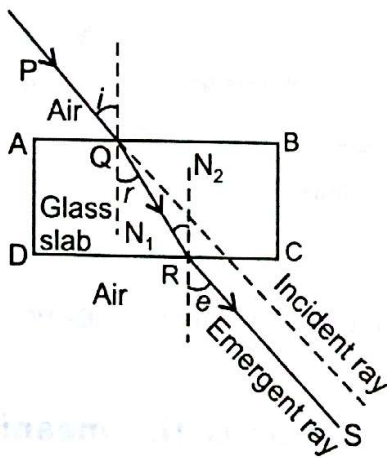

Apply Snell's law at Q on the side AB

$$\frac{\sin i}{\sin r} = \frac{n_g}{n_a} = {}_a n_g \quad \dots (1)$$

Apply Snell's law at R on the side DC

$$\frac{\sin r}{\sin i} = \frac{n_a}{n_g} = {}_g n_a \quad \dots (2)$$

$$[\angle N_1QR = \angle QRN_2 = r, \text{ alt. angles}]$$

If the ray retraces its entire path, then for reversed ray

$$\frac{n_g}{n_a} = \frac{\sin e}{\sin r} = {}_a n_g \quad \dots (3)$$

Multiplying (2) by (3), we get

$$\frac{\sin r}{\sin e} \times \frac{\sin e}{\sin r} = {}_g n_a \times {}_a n_g = 1$$

Due to this property, we say refraction of light is reversible.

From (1) and (3),

$$\frac{\sin i}{\sin r} = \frac{\sin e}{\sin r} \quad \dots (4)$$

$$\Rightarrow \sin i = \sin e$$

$$\text{or } \angle i = \angle e$$

Hence incident ray PQ is parallel to the emergent ray RS when light falls obliquely on a side of rectangular glass slab.

**52. With the help of a ray diagram explain why a convex mirror is preferred for rear view mirrors in motor cars.**

[Foreign]

- Ans.**
- It always forms a virtual, erect and diminished image.
  - The field of view increases while using a convex mirror as shown.

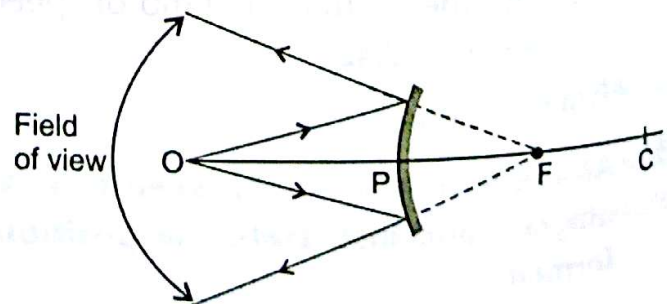



53. What is understood by lateral displacement of light? Illustrate it with the help of a diagram. List any two factors on which the lateral displacement of a particular substance depends. [Foreign]

Ans. Lateral displacement is the perpendicular distance between the incident ray produced and the emergent ray. Lateral displacement in the diagram is BL. The lateral displacement depends on the thickness of the slab, the incident and refraction angles.

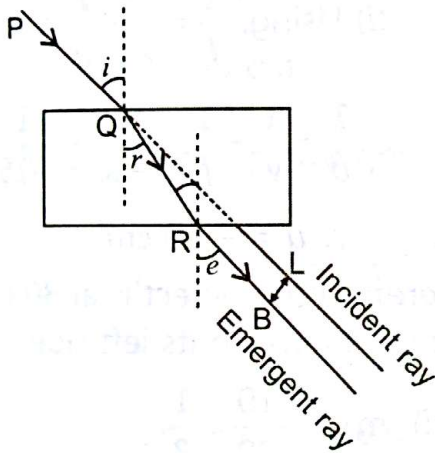

54. Draw the ray diagram and also state the position, relative size and nature of the image formed by a concave mirror when the object is placed between its centre of curvature, C and focus, F. [Foreign]

Ans.

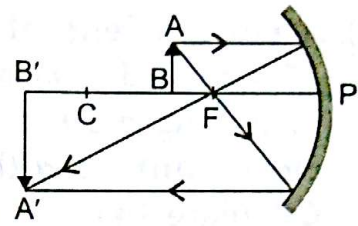

**Position of object:** Between F and C

**Position of image:** Beyond C

**Nature of image:** Real, inverted and enlarged.

### LONG ANSWER TYPE QUESTIONS

[5 Marks]

55. (a) If the image formed by a lens is diminished in size and erect, for all positions of the object, what type of lens is it?

(b) Name the point on the lens through which a ray of light passes undeviated.

(c) An object is placed perpendicular to the principal axis of a convex lens of focal length 20 cm. The distance of the object from the lens is 30 cm. Find (i) the position (ii) the magnification and (iii) the nature of the image formed.

Ans.

(a) Concave lens.

(b) Optical centre.

(c)  $u = -30$  cm,  $f = 20$  cm

[Delhi]

(i) Using,  $\frac{1}{f} = \frac{1}{v} - \frac{1}{u}$  we get,

$$\frac{1}{v} = \frac{1}{f} + \frac{1}{u} = \frac{1}{20} + \frac{1}{-30} = \frac{3-2}{60}$$

$$\Rightarrow v = 60 \text{ cm}$$

Image is formed at a distance of 60 cm from the lens on the right side.

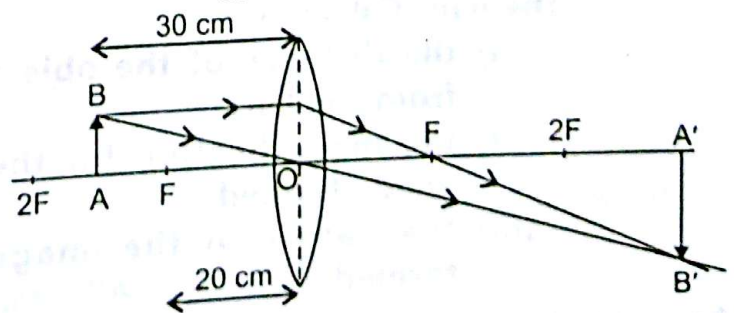

$$(ii) m = \frac{v}{u} = \frac{60}{-30} = -2$$

So, image is inverted and double the size of the object.

(iii) Image is real as  $v > 0$ , inverted and enlarged.

56. (a) What is meant by 'power of a lens'?

(b) State and define the S.I. unit of power of a lens.

(c) A convex lens of focal length 25 cm and a concave lens of focal length 10 cm are placed in close contact with each other. Calculate the lens power of this combination. [All India]

Ans. (a) The ability of a lens to converge or diverge the ray of light after refraction is called power (P) of the lens. It is defined as the reciprocal of the focal length, i.e.  $P = \frac{1}{f}$ .

(b) The SI unit of power of a lens is 'diopetre'. A lens of focal length 100 cm has a power of 1 diopetre, i.e. 1 diopetre =  $1 \text{ m}^{-1}$ .

(c) Power of the combination

$$= P = P_1 + P_2$$

$$= \frac{100}{25} + \frac{100}{-10}$$

$$= 4 - 10 = -6 \text{ D.}$$

57. (a) Draw a ray diagram to show the formation of image of an object placed between infinity and the optical centre of a concave lens.

(b) A concave lens of focal length 15 cm forms an image 10 cm from the lens. Calculate

(i) the distance of the object from the lens.

(ii) the magnification for the image formed.

(iii) the nature of the image formed. [All India]

Ans. (a) Image formation when the object is at any position between infinity and optical centre:

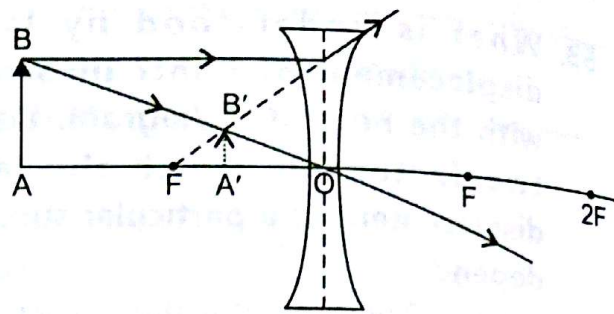

**Position of image:** Between F and optical centre

**Nature of image:** Virtual, erect and diminished.

(b)  $f = -15 \text{ cm}$     $v = -10 \text{ cm}$

(i) Using,  $\frac{1}{f} = \frac{1}{v} - \frac{1}{u}$ , we get

$$\frac{1}{u} = \frac{1}{v} - \frac{1}{f} = \frac{1}{-10} - \frac{1}{-15} = -\frac{1}{30}$$

$$\therefore u = -30 \text{ cm}$$

Therefore the object is at 30 cm from the concave lens on its left side.

(ii)  $m = \frac{-10}{-30} = \frac{1}{3}$

(iii)  $m$  is +ve, so image is erect.  $v$  is -ve, so image is virtual. As  $m < 1$ , image is diminished.

58. (a) Under what condition will a glass lens placed in a transparent liquid become invisible?

(b) Describe and illustrate with a diagram, how we should arrange two converging lenses so that a parallel beam of light entering one lens emerges as a parallel beam after passing through the second lens.

(c) An object is placed at a distance of 3 cm from a concave lens of focal length 12 cm. Find the (i) position and (ii) nature of the image formed. [Foreign]

Ans. (a) When the refractive index of glass lens becomes equal to the refractive index of transparent liquid, the glass lens will become invisible.

(b) Parallel beam converges at focus of the first lens and emerges parallel as it is at the focus of second lens.

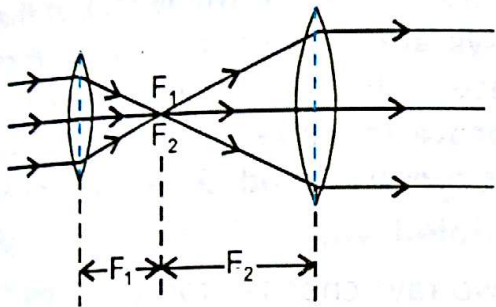

(c)  $f = -12$  cm,  $u = -3$  cm

(i) Using  $\frac{1}{f} = \frac{1}{v} - \frac{1}{u}$ , we get

$$\frac{1}{v} = \frac{1}{f} + \frac{1}{u} = \frac{1}{-12} - \frac{1}{3} = \frac{-1-4}{12}$$

$$\Rightarrow v = -\frac{12}{5} \text{ cm}$$

(ii)  $v < 0$ , so image is virtual.

$|v| < |u|$ , so image is diminished.

$$m = \frac{v}{u} = \frac{-\frac{12}{5}}{-3} = \frac{4}{5}$$

$m > 0$  but  $|m| < 1$ , so, image is erect and diminished.

59. (a) With the help of a ray diagram explain why a concave lens diverges the rays of a parallel beam of light.

(b) A 2.0 cm tall object is placed perpendicular to the principal axis of a concave lens of focal length 15 cm. At what distance from the lens, should the object be placed so that it forms an image 10 cm from the lens? Also find the nature and the size of image formed.

[Foreign]

Ans. (a) When a parallel beam of light incident on a front face of concave

lens, each ray of light will refract towards the normal to the surface as it moves from rarer to denser medium and travels in a straight line inside the lens until it reaches the back face of the lens. At the back face boundary, each ray of light will again refract and bend away from the normal to the surface as it moves from denser to rarer medium. The course of ray of light is shown in the following figure.

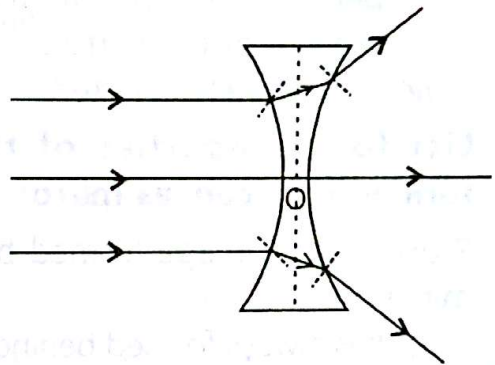

Thus, because of the concave shape of both the faces, the double concave lens diverge the rays of parallel beam of incident light.

(b)  $h_o = 2.0$  cm,  $f = -15$  cm

$v = -10$  cm as concave lens always forms virtual image.

Using,  $\frac{1}{f} = \frac{1}{v} - \frac{1}{u}$ , we get

$$\frac{1}{u} = \frac{1}{v} - \frac{1}{f} = \frac{1}{-10} - \frac{1}{-15} = \frac{-15+10}{150}$$

$$\Rightarrow u = -\frac{150}{5} = -30 \text{ cm}$$

Using,  $m = \frac{h_i}{h_o} = \frac{v}{u}$ , we get

$$m = \frac{-10}{-30} = \frac{1}{3} < 1, \text{ we get}$$

$$h_i = 2 \times \frac{-10}{-30} = \frac{2}{3}$$

So, image is virtual, erect and diminished.

## SHORT ANSWER TYPE QUESTIONS[I]

[2 Marks]

60. List four properties of the image formed by a plane mirror. [Delhi]

Ans. Properties of image formed by a plane mirror:

- (i) It is always virtual and erect.
- (ii) Its size is equal to that of the object.
- (iii) It is formed at the same distance behind the mirror as the object is in front of the mirror.
- (iv) It is laterally inverted.

61. List four properties of the image formed by a convex mirror. [Delhi]

Ans. Properties of image formed by a convex mirror:

- (i) It is always formed behind the mirror, between the pole and its focus.
- (ii) It is always virtual and erect.
- (iii) Its size is always smaller than the object.
- (iv) Magnification is always positive.

62. List four properties of the image formed by a concave mirror, when object is placed between focus and pole of the mirror. [Delhi]

Ans. (i) The image is formed behind the mirror.

- (ii) It is enlarged, i.e. magnified.
- (iii) It is virtual.
- (iv) It is erect.

63. To construct a ray diagram, we use two light rays which are so chosen that it is easy to know their directions after refraction from the lens. List these two rays and state the path of these rays after refraction. Use these two rays to locate the image of an object placed between 'F' and '2F' of a convex lens. [Foreign]

Ans. Two rays chosen for refraction:

- (i) A ray of light parallel to the principal axis.
- (ii) A ray of light passing through the optical centre of a lens.

Path of these rays after refraction:

In case of convex lens, the first ray will pass through the principal focus on the other side of the lens.

In case of concave lens, the first ray will

- (a) appear to diverge or
- (b) appear to come from the principal focus positioned on the same side of the object.

The second ray emerge from the lens without any deviation in the path.

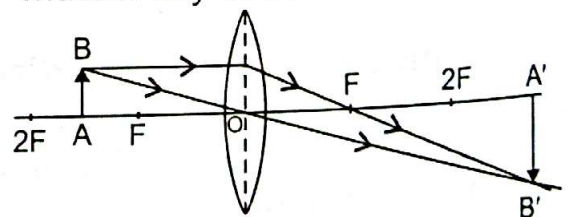

## SHORT ANSWER TYPE QUESTIONS[II]

[3 Marks]

64. State the type of mirror preferred as (i) rear view mirror in vehicles, (ii) shaving mirror. Justify your answer giving two reasons in each case. [Delhi]

Ans. (i) Convex mirror  
(ii) Concave mirror

Justification:

- (i) Convex mirror is used as a rear view mirror because:
  - (a) it gives a wider field of view as it is curved outwards and
  - (b) it produces erect and diminished image of the traffic behind the driver of the vehicle.

(ii) Concave mirror is used as a shaving mirror to see a large size image of the face. When the object lies in between pole and principal focus of a concave mirror, it forms a virtual, erect and enlarged image behind it.

65. The image of a candle flame placed at a distance of 45 cm from a spherical lens is formed on a screen placed at a distance of 90 cm from the lens. Identify the type of lens and calculate its focal length. If the height of the flame is 2 cm, find the height of its image. [Delhi]

Ans. Nature of spherical lens = convex lens

Given:  $u = -45$  cm,  $v = +90$  cm,

$h_1 = +2$  cm

Using lens formula,

$$\frac{1}{f} = \frac{1}{v} - \frac{1}{u}$$

$$= \frac{1}{90} - \frac{1}{-45} = \frac{1}{90} + \frac{1}{45}$$

$$= \frac{1+2}{90} = \frac{3}{90} = \frac{1}{30}$$

$\therefore f = +30$  cm

So, focal length of convex lens is 30 cm.

Again,

$$m = \frac{h_2}{h_1} = \frac{v}{u}$$

$$\Rightarrow h_2 = \frac{v}{u} \times h_1 = \frac{90}{-45} \times 2 = -4 \text{ cm}$$

So, height of image is 4 cm. Negative sign indicates that it is formed below the principal axis.

66. A 4 cm tall object is placed perpendicular to the principal axis of a convex lens of focal length 24 cm. The distance of the object from the lens is 16 cm. Find the position, size and nature of the image formed, using the lens formula. [All India]

Ans. For convex lens

$f = +24$  cm,  $u = -16$  cm

Using lens formula,

$$\frac{1}{f} = \frac{1}{v} - \frac{1}{u}$$

$$\frac{1}{24} = \frac{1}{v} - \frac{1}{-16} = \frac{1}{v} + \frac{1}{16}$$

$$\therefore \frac{1}{v} = \frac{1}{24} - \frac{1}{16} = \frac{2-3}{48} = -\frac{1}{48}$$

$$v = -48 \text{ cm}$$

Now  $h_1 = 4$  cm

So, magnification,

$$m = \frac{h_2}{h_1} = \frac{v}{u}$$

$$\Rightarrow h_2 = \frac{v}{u} \times h_1 = \frac{-48}{-16} \times 4$$

$$= +12 \text{ cm}$$

**Position of image:** Image is formed at a distance of 48 cm from the optical centre of the lens on the same side of the object. It is indicated by the negative sign.

**Size of image:** It is three times the size of object, i.e. 12 cm.

**Nature of image:** Positive sign in the image height indicates that image is virtual and erect.

67. Name the type of mirror used in the following situations:

(i) Headlights of a car

(ii) Rear-view mirror of vehicles

(iii) Solar furnace

Support your answer with reason.

[All India][Foreign]

Ans. Type of mirror used in

(i) Headlights of a car: Concave mirror  
Concave mirror is used because light from the bulb placed at the focus of it gets reflected and produces a powerful parallel beam of light to illuminate the road.

(ii) Rear view mirror of vehicles: Convex mirror

Convex mirror is used because it always produces a virtual, and erect image whose size is smaller than the object. Therefore it enables the driver to see wide field view of the traffic behind the vehicle in a small mirror.

(iii) Solar furnace: Concave mirror

Concave mirror has the property to concentrate the sunlight coming from sun along with heat radiation at its focus. As a result, temperature at its focus increases and the substance placed at the focal point gets heated to a high temperature.

**68. A 6 cm tall object is placed perpendicular to the principal axis of a convex lens of focal length 15 cm. The distance of the object from the lens is 10 cm. Find the position, size and nature of the image formed, using the lens formula.**

[Foreign]

**Ans.** For convex lens

$$f = +15 \text{ cm}, u = -10 \text{ cm}$$

Using lens formula,

$$\frac{1}{f} = \frac{1}{v} - \frac{1}{u}$$

$$\frac{1}{15} = \frac{1}{v} - \frac{1}{-10} = \frac{1}{v} + \frac{1}{10}$$

$$\therefore \frac{1}{v} = \frac{1}{15} - \frac{1}{10} = \frac{2-3}{30} = -\frac{1}{30}$$

$$v = -30 \text{ cm.}$$

Thus, the image is formed on the same side of the object at a distance of 30 cm from the optical centre of the lens.

Negative sign indicates that image is virtual.

Now  $h_1 = +6 \text{ cm}$

So using,

$$m = \frac{h_2}{h_1} = \frac{v}{u}$$

$$\Rightarrow h_2 = \frac{v}{u} \times h_1 = \frac{-30}{-10} \times 6 = +18 \text{ cm}$$

So, image is three times larger than the size of object, i.e. 18 cm.

The positive sign indicates that the image is erect.

[5 Marks]

## LONG ANSWER TYPE QUESTIONS

**69. List the sign conventions for reflection of light by spherical mirrors. Draw a diagram and apply these conventions in the determination of focal length of a spherical mirror which forms a three times magnified real image of an object placed 16 cm in front of it. [Delhi]**

**Ans.** Sign conventions for reflection of light by spherical mirror are:

(i) The object is always placed to the left of the mirror.

(ii) All the distances parallel to the principal axis are always measured from the pole of the spherical mirror.

(iii) All the distances measured along the direction of incident light (along +ve x-axis), are considered to be positive.

(iv) Those distances measured opposite to the direction of incidence light (i.e. along -ve x-axis), are taken as negative.

(v) The distances measured in upward direction, i.e. perpendicular to and above the principal axis (along +ve y-axis), are taken as positive.

(vi) The distances measured in the downward direction, (along -ve y-axis), i.e. perpendicular to and below the principal axis are taken as negative.

From the question

$u = -16$  cm,  $m = -3$  for real image

But  $m = -\frac{v}{u} = -3$

$\Rightarrow v = 3u = 3(-16) = -48$  cm.

Using mirror formula,

$$\frac{1}{f} = \frac{1}{v} + \frac{1}{u}$$

We get,  $\frac{1}{f} = \frac{1}{-48} + \frac{1}{-16}$   
 $= \frac{1}{-48} - \frac{1}{16} = \frac{-1-3}{48} = \frac{-4}{48} = \frac{-1}{12}$

or  $f = -12$  cm

So, focal length of spherical mirror is 12 cm. Negative sign of focal length indicates that mirror is concave in nature.

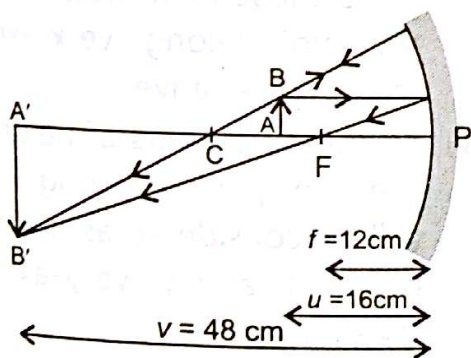

70. State the law of refraction of light that defines the refractive index of a medium with respect to the other. Express it mathematically. How is refractive index of any medium 'A' with respect to a medium 'B' related to the speed of propagation of light in two media A and B? State the name of this constant when one medium is vacuum or air.

The refractive indices of glass and water with respect to vacuum are  $3/2$  and  $4/3$  respectively. If the speed of light in glass is  $2 \times 10^8$  m/s, find the speed of light in (i) vacuum, (ii) water. [Delhi]

**Ans. Snell's law:** The ratio of sine of angle of incidence (i.e.  $\sin i$ ) to the sine of angle of refraction (i.e.  $\sin r$ ) is always constant for the light of given colour and for the given pair of media.

Mathematically,

$$\frac{\sin i}{\sin r} = \text{constant} = n_{21}$$

The constant ' $n_{21}$ ' is called refractive index of the second medium with respect to the first medium.

- Refractive index of medium 'A' with respect to medium 'B' is represented by  $n_{AB}$ . It is given by

$$n_{AB} = \frac{\text{Speed of light in medium 'B'}}{\text{Speed of light in medium 'A'}} = \frac{v_B}{v_A}$$

- If one medium is vacuum or air, then the refractive index of the second medium with respect to vacuum or air is called absolute refractive index of the medium,  $n_m$ .

Thus,

$$n_m = \frac{\text{Speed of light in air or vacuum}}{\text{Speed of light in medium}} = \frac{c}{v}$$

- Given:  $n_g = \frac{3}{2}$ ,  $n_w = \frac{4}{3}$

$v_g = 2 \times 10^8 \text{ ms}^{-1}$ ,  $c = ?$ ,  $v_w = ?$

From the above relation,

$$n_g = \frac{c}{v} \Rightarrow \frac{3}{2} = \frac{c}{2 \times 10^8}$$

$\Rightarrow c = 3 \times 10^8 \text{ m/s}$

So, speed of light in vacuum is  $3 \times 10^8$  m/s.

Also,  $n_w = \frac{c}{v_w}$

$$\Rightarrow \frac{4}{3} = \frac{3 \times 10^8}{v_w}$$

$$\Rightarrow v_w = \frac{9}{4} \times 10^8 = 2.25 \times 10^8 \text{ m/s}$$

So, speed of light in water is  $2.25 \times 10^8$  m/s.

**71. To construct a ray diagram, we use two light rays which are so chosen that it is easy to know their directions after reflection from the mirror. List these two rays and state the path of these rays after reflection. Use these rays to locate the image of an object placed between centre of curvature and focus of a concave mirror. [All India]**

**Ans.** Rays which are chosen to construct ray diagram for reflection are:

- (i) A ray parallel to the principal axis and
- (ii) A ray passing through the centre of curvature of a concave mirror or appear to pass through the centre of curvature of convex mirror.

Path of these rays after reflections is:

- (i) After reflection, the first ray will pass through the principal focus of a concave mirror or appear to diverge in case of a convex mirror.
- (ii) After reflection, the second ray is reflected back along the same path.

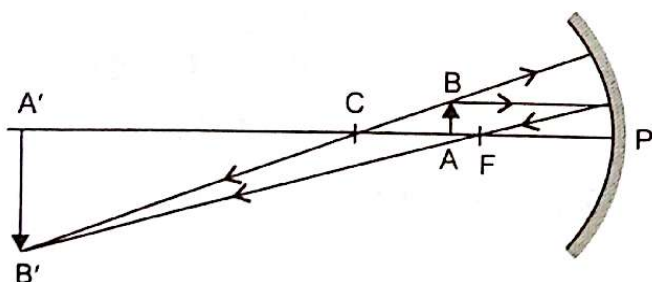

**72. List the sign conventions that are followed in case of refraction of light through spherical lenses. Draw a diagram and apply these conventions in determining the nature and focal length of a spherical lens which forms three times magnified real image of an object placed 16 cm from the lens. [Foreign]**

**Ans.** Sign conventions for refraction of light through spherical lens are:

- (i) The object is always placed to the left of the lens so that incident light moves from left to right.
- (ii) All distances are to be measured from the optical centre of the lens.
- (iii) The distances measured in the direction of incident light (along +ve x-axis) will be taken as positive while those measured to the left of the origin (along -ve x-axis) will be taken as negative.
- (iv) All measurements of heights above the principal axis (along +ve y-axis) will be considered as positive while below it (along -ve y-axis) will be taken as negative.

• According to question,

$$u = -16 \text{ cm}, m = -3$$

(real image)

$$\text{But } m = \frac{v}{u}$$

$$= -3$$

$$\Rightarrow v = -3u$$

$$= -3 \times (-16)$$

$$= 48 \text{ cm.}$$



Using lens formula,

$$\frac{1}{f} = \frac{1}{v} - \frac{1}{u}$$
$$= \frac{1}{48} - \frac{1}{-16} = \frac{1}{48} + \frac{1}{16}$$
$$= \frac{1+3}{48} = \frac{4}{48} = \frac{1}{12}$$

$$\Rightarrow f = +12 \text{ cm}$$

So, focal length of the given spherical lens is 12 cm. The positive sign of focal length shows that the nature of spherical lens is convex.

**Ray diagram:**

